

GaN 90-95 GHz PA

Preliminary Datasheet

Product Features

- Frequency Range: 90-95 GHz
- Psat: 0.5 W
- Gain: 14 dB
- PAE: 15%
- Bias: Vd=12V, Id=210 mA
- Chip dimensions: 3.4 x 1.35 x 0.05 mm

Primary Applications

- W-band high data rate wireless links
- Sensors and Radars

Product Description

The HRL G94-PA is a three stage power amplifier fabricated using HRL's T-gate GaN HEMT process (GaN-on-SiC). The amplifier has independent gate and drain bias for each stage. Front-side bond pads (RF and DC) and backside metallization are Ti/Au, which is compatible with conventional wire and ribbon bonding techniques, and die attach processes.

The G94-PA typically provides 0.5 W output power with 15 dB small signal gain and a PAE of 15% at 92 GHz.

Typical Measured Performance

Vd=12V, Id1=30mA, Id2=60mA, Id3=120mA

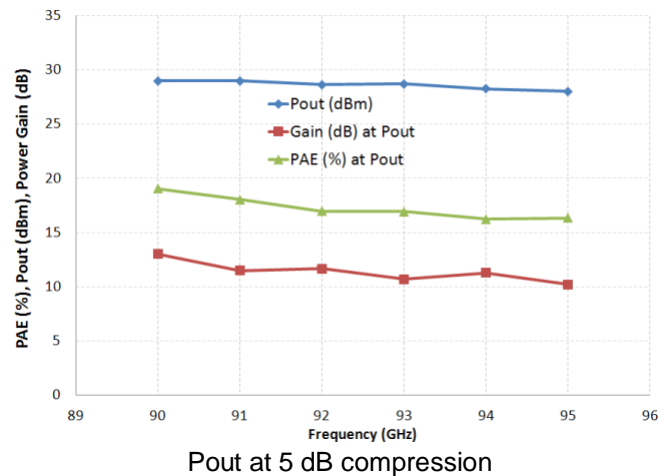
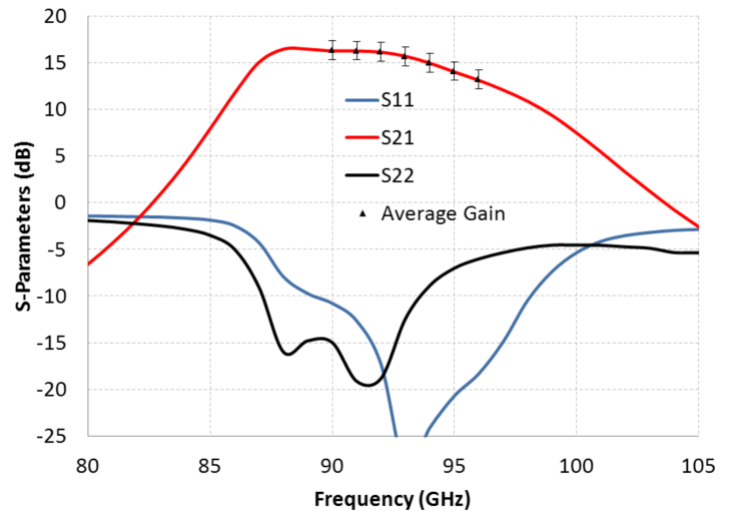

Electrical Specifications

Vd=12V, Id1=36mA, Id2=70mA, Id3=144mA

Specification	Min	Typ	Max	Unit
Frequency	90		95	GHz
Linear Gain	13	14	16	dB
Input Return Loss		8		dB
Output Return Loss		6		dB
Saturated Output Power		27		dBm

Disclosure Information: This document is for information only. HRL Laboratories reserves the right to change without notice the characteristic data and other specifications as they apply to the product(s). The product(s) represented by this document is subject to U.S. Export Law as contained in ITAR or the EAR regulations. HRL Laboratories makes no warranty, representation or guarantee regarding the suitability of its products for any particular purpose, nor does HRL Laboratories assume any liability whatsoever arising out of the use or application of any product(s) or information.

6/28/2019

©2019 HRL Laboratories, LLC

<http://mmics.hrl.com>

mmics@hrl.com

Absolute Maximum Ratings CW Operation

Parameter	Rating	Unit
Input Power (Pin)	20	dBm
Drain Voltage (Vd)	12	V
Gate Voltage Range (Vg)	-1 to -3.5	V
Drain Current (Id)	300	mA
Die Attach Temperature (30 sec)	290	°C

Exceeding any one or combination of the Absolute Maximum Ratings may result in permanent damage to the device. Application of Absolute Maximum Ratings on the device for an extended period of time may negatively affect the reliability of the device.

Caution: ESD sensitive device.

Outline Drawing

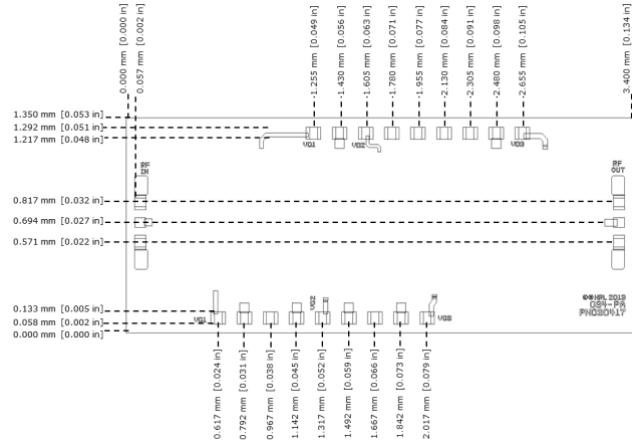

DC Bond Pads are 0.1mm²; Bond pad locations shown from die etch to pad center.

Pout, PAE and Gain vs. Pin at 92 GHz

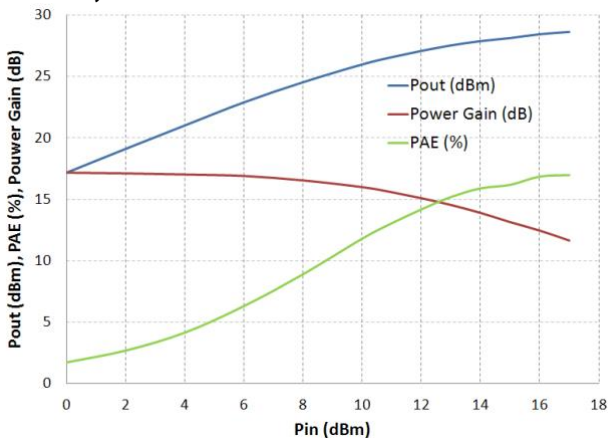

Biasing Procedure

Turn on

- 1) Vg1 = Vg2 = Vg3 = - 6 V
- 2) Vd1 = Vd2 = Vd3 = 12 V
- 3) Adjust Vg1 to obtain Id1 = 30 mA
- 4) Adjust Vg2 to obtain Id2 = 60 mA
- 5) Adjust Vg3 to obtain Id3 = 120 mA

Turn off

- 1) Vd1 = Vd2 = Vd3= 0V
- 2) Vg1 = Vg2 = Vg3= 0V

Recommended Assembly Diagram

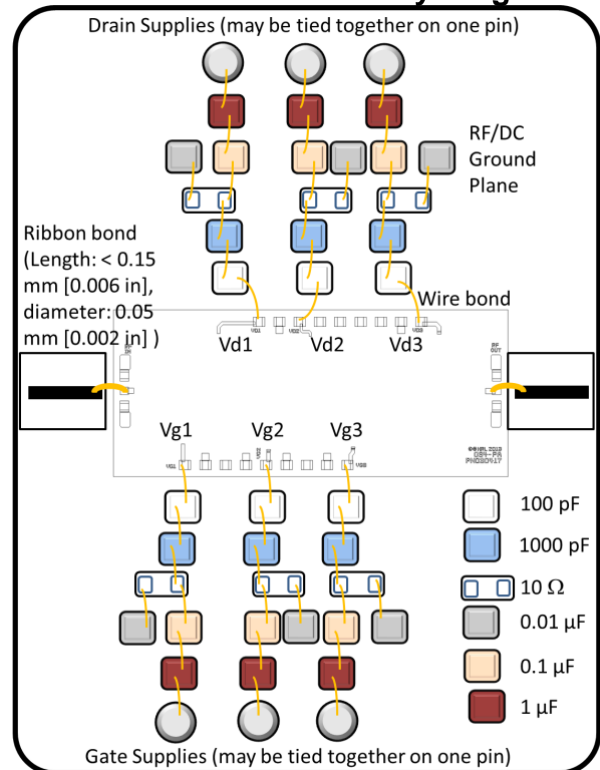

HRL recommends mounting the die on CuW heat spreader using AuSn eutectic solder.

Disclosure Information: This document is for information only. HRL Laboratories reserves the right to change without notice the characteristic data and other specifications as they apply to the product(s). The product(s) represented by this document is subject to U.S. Export Law as contained in ITAR or the EAR regulations. HRL Laboratories makes no warranty, representation or guarantee regarding the suitability of its products for any particular purpose, nor does HRL Laboratories assume any liability whatsoever arising out of the use or application of any product(s) or information.

6/28/2019

©2019 HRL Laboratories, LLC

<http://mmics.hrl.com>

mmics@hrl.com